

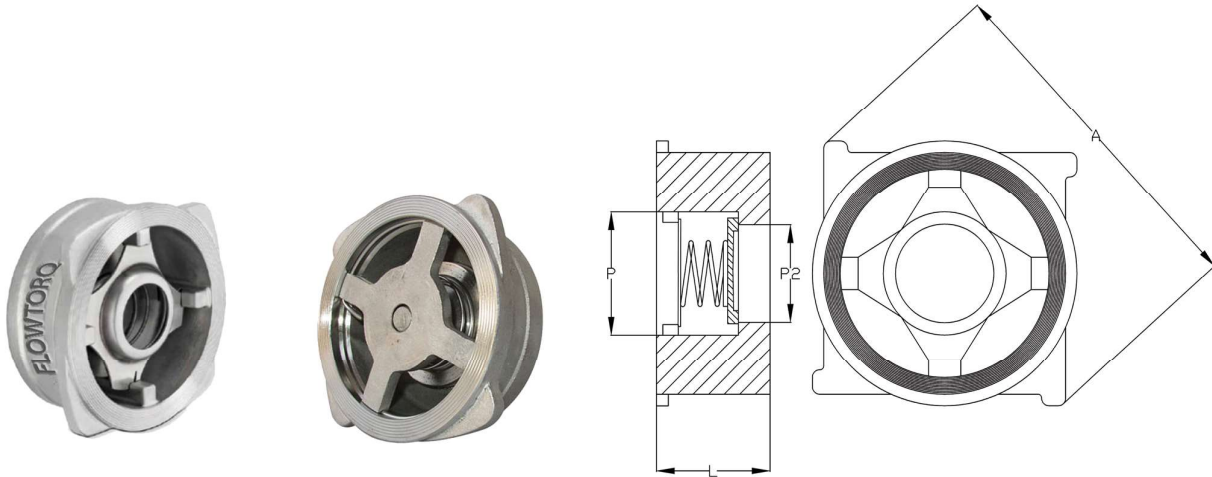

CHECK VALVES - SPRING LOADED DISC CHECK VALVES



A development with a combination of Dual Plate Check Valve and Wafer Type Check Valve, Spring Loaded Disc Check Valves houses a disc which is loaded against body by spring force. The body houses the spring, disc, stopper pins and screwed part as a retainer. Suited for high pressure and low pressure applications in oil & gas, petrochemical, chemical, power and other process industries. Ideal solution for applications where space constraints and weight constraints are critical. Can be used in vertical, horizontal and angular orientations as well.



Upto - 20 Bar						
Size		P	P2	L	A	D
DN	Inch					
15	1/2"	29	15	19	60	38
20	3/4"	36	20	19	70	45
25	1"	44	25	2	80	56
32	1.25"	55	32	28	90	65
40	1.5"	66	40	31	98	74
50	2"	77	50	40	112	85
65	2.5"	98	65	46	141	107
80	3"	111	80	50	151	122
100	4"	130	100	60	181	142
125	5"	161	125	90	215	170
150	6"	190	150	105	255	202
200	8"	250	200	140	320	261

(Code - AZV)

DESIGN STANDARD	
Check Valve	ASME B16.34, Mnfr's Std
Face to Face / End to End Dimensions	API6D, ASME B16.34, Mnfr's Std
Valve inspection & testing	API598, BS 5146
Pressure - Temperature rating	ASME B16.34